



GAS DETECTOR

ST650-CO₂

PART.NO. 1226030-1226036

DETECTION OF CARBON DIOXIDE

SYSTEM CGD50, CGD500 Touch

GENERAL DESCRIPTION

- Detection of Carbon Dioxide (CO₂)
- All-round industrial gas detector
- ATEX / IECEx approved / Type Approval
- Touch screen experience, control without additional tools
- Self-diagnostics
- Reliable sensor technology

The **ST650-CO₂** is an all-round gas detector which is suitable for a large number of applications where Carbon Dioxide forms a risk. The heart of the detector is a replaceable gas sensor. The measuring principle consists of an Infrared sensor (NDIR) with a high durability. The sensor offers a long term stability and has a long life-span, which achieves an optimal cost of ownership.

The **ST650-CO₂** is available with or without a graphic display. The version with a graphic display, shows the measured value and various status notifications locally. The capacitive key control gives you an experience similar to a touchscreen and enables easy navigation through the user/calibration menu. The user menu is secured with a password; unauthorized users cannot access the gas detector. The control of the user/calibration menu does not require additional tools (for example magnets). Simple, easy and user friendly!

The user menu provides different features, such as a zero and span calibration, adjusting alarm set points (local alarm indication through notifications on the display and colored LED), showing set points, diagnostic information and simulation of the output signal (4-20mA) for loop testing.

HEIGHTS AREAS / REMOTE APPLICATIONS:

The remote application enables the possibility to mount the sensor separately from the transmitter. Remote applications are ideal for detection zones which are difficult to access for example maintenance. These detection zones could be: for example ventilation ducts at high locations, basements or silos. When using the remote applications, the sensor will be mounted at a high location on the ceiling and the transmitter will be placed within reach. Hereby fast and easy periodic maintenance is made possible and therefore cost reducing. Cable lengths up to 150 meters are supported for the remote sensor depending on the type.

APPLICATIONS:

- + Food industry
- + Water Industry
- + Medical Industry
- + Fermentation processes
- + Marine
- + Chemical industry
- + Laboratories

WE OFFER MORE THAN A PRODUCT!

- + Tailored advice
- + Project advice
- + Technical support
- + Training and education
- + Commissioning
- + Onsite service / maintenance / calibration



Standard version



LCD version



Remote / LCD version

ORDERING INFORMATION

GAS DETECTOR								
TYPE	APPLICATION	SENSOR TYPE	RANGE	PART NO.				
				STANDARD	REMOTE *	LCD	ALU or SS**	
ST650-CO ₂ 5 Vol.%	Standard	NDIR	0-5 Vol.% CO ₂	1226030	.../R	.../LCD	.../AI	.../SS
ST650-CO ₂ 10 Vol.%	Standard	NDIR	0-10 Vol.% CO ₂	1226033	.../R	.../LCD	.../AI	.../SS
ST650-CO ₂ 100 Vol.%	Standard	NDIR	0-100 Vol.% CO ₂	1226035	.../R	.../LCD	.../AI	.../SS
ST650-CO ₂ 1 Vol.%	Standard	NDIR	0-1 Vol.% CO ₂	1226036	.../R	.../LCD	.../AI	.../SS

* Including 10 meter tubing
 ** Standard delivered as aluminium housing

EXAMPLE

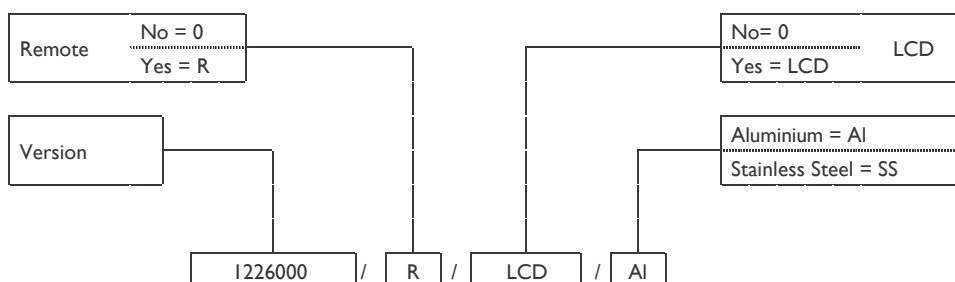

Article no. example: ST650EX-3 remote version, with LCD, aluminium housing: **1226000/R/LCD/AI**

ACCESSORIES

TYPE	IMAGE	PART NO.	DESCRIPTION
Signal cable		4002426	4 core shielded cable, 4x0,75 mm ² (flexible cores, 3+PE), per meter
Duct mounting set		4002723	Duct mounting set for mounting in ventilation ducts
Splash Guard		4002712	Environmental sensor protection, incl. splash water
Inline flow adapter		4002720	Inline flow adapter for sample applications, connection 2x6mm, SS
Protective hood		4002714	Protective hood SS, for optimal protection in "wet" production areas, dim. 315x300x138 mm
Isolation set EMC/RFI		4002440	Isolation plate EMC/RFI, 160x160 mm
Protective bracket		4002713	SS bracket, extra protection for use in e.g. warehouses

SPARE PARTS / CONSUMABLES

SPARE GAS SENSOR	PART NO.	RANGE	APPLICATION	DESCRIPTION
Type IRs CO ₂	1219620	0-5 Vol.% CO ₂	Standard only	Infrared sensor (NDIR), Carbon dioxide
Type IRs CO ₂	1219620/V	0-5 Vol.% CO ₂	Remote only	Infrared sensor (NDIR), Carbon dioxide
Type IRs CO ₂	1219670/V	0-1 Vol.% CO ₂	Standard & Remote	Infrared sensor (NDIR), Carbon dioxide
Type IRs CO ₂	1219671/V	0-10 Vol.% CO ₂	Standard & Remote	Infrared sensor (NDIR), Carbon dioxide
Type IRs CO ₂	1219673/V	0-100 Vol.% CO ₂	Standard & Remote	Infrared sensor (NDIR), Carbon dioxide

TEST GASES AND ACCESSORIES

TYPE	PART NO.	DESCRIPTION
BUGAS, 1,0Vol.% CO ₂	9990548	Carbon dioxide 1 Vol.% in air, 110 gas liters
BUGAS, 2,5Vol.% CO ₂	9990544	Carbon dioxide, 2 Vol.% in air, 110 gas liters
BUGAS, 3,5 Vol.% CO ₂	9990565	Carbon dioxide, 10 Vol.% in air, 110 gas liters
BUGAS, N ₂	9990524	Nitrogen, 100 Vol.%, 110 gas liters
Calibration adapter	4002715	Stainless Steel / calibration flow adapter
Gas hose	1225819	Flexible tubing, Ø 6mm, per meter
Flow regulator	9990600	Flow regulator Chrome/brass, fixed flow 0,5 l/min
Flow regulator	9990601	Flow regulator Stainless Steel, fixed flow 0,5 l/min

Consilium offers a wide range of test gases, if the required test gas is not listed, please contact us.

CONNECTION DIAGRAM GAS DETECTOR

ST650-CO₂ used as 4-20mA transmitter (3 wires):

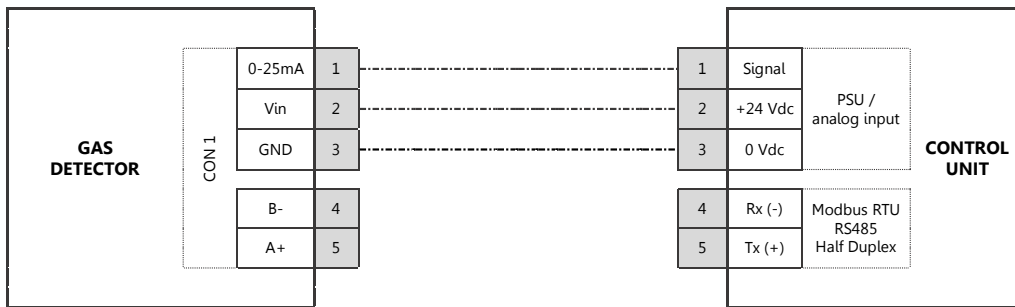

ST650-CO₂ used as MODBUS slave device:

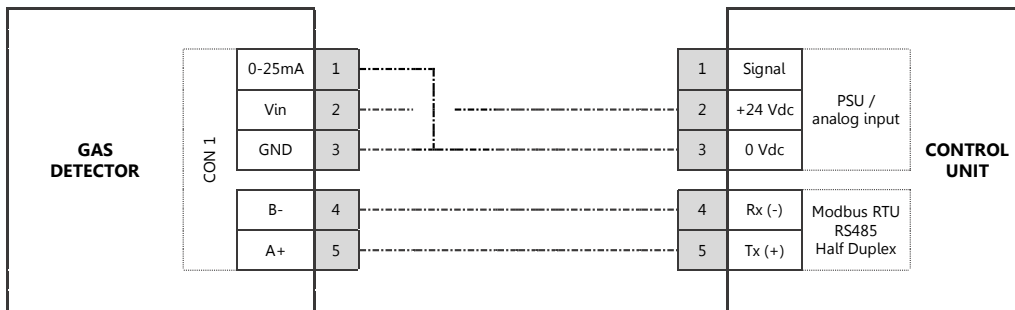

ST650-CO₂ used as MODBUS slave device and 3 wire 4-20 mA transmitter:

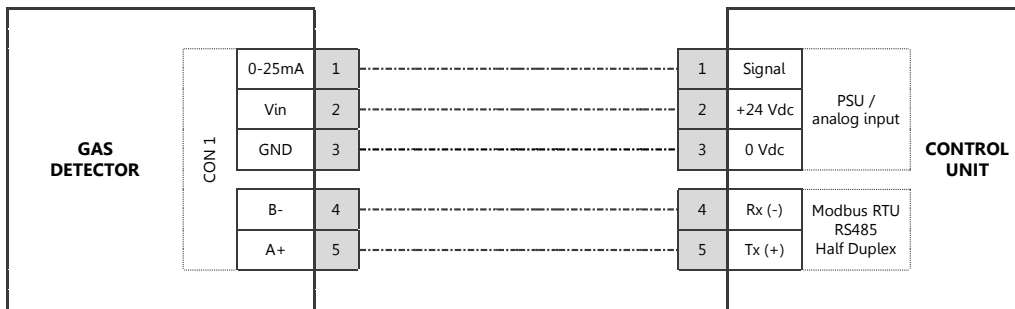

DIMENSIONS

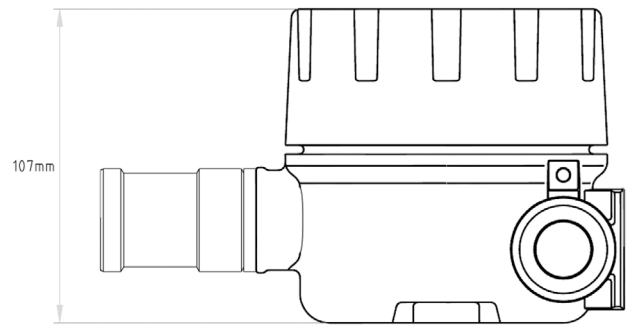
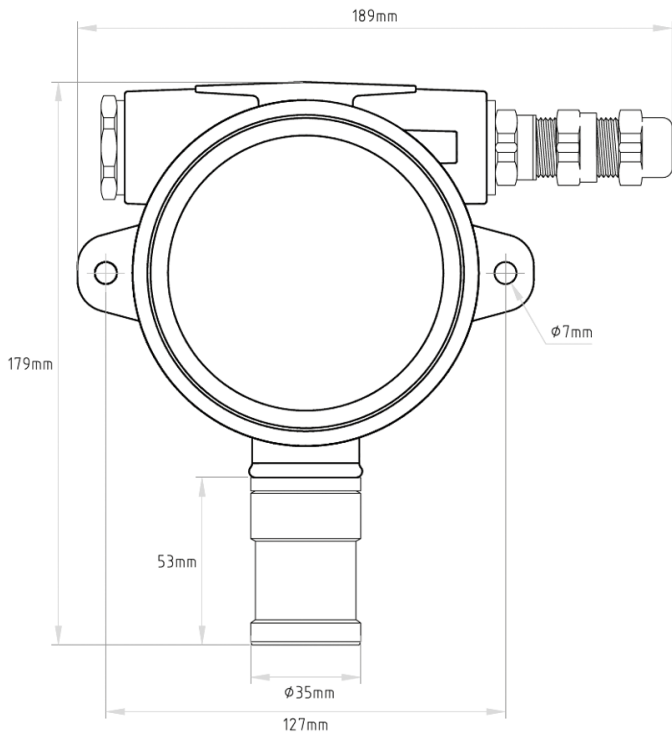

SPECIFICATIONS

PRODUCT	ST650 CO ₂
Gas type	Carbon dioxide (CO ₂)
Measuring principle	See detector type
Range	0-5 Vol.%
Display (optional)	Digital graphic display with backlight
Status LED display	Green: OK, Red: Alarm, Yellow: SF (System Failure), Blue: User menu active
Power supply	17.5-24VDC (max. 120 mA)
Outputs	Analogue: 4-20 mA (2 mA system failure, >20 mA overrange) Digital: RS485 Modbus RTU (half-duplex)
Signal cable	3-wire shielded, 0.75 ... 2.5 mm ² (excluding earth connection and Modbus)
Cable gland	Standard Brass, optional SS (thread M20x1.5)
Load impedance	max. 400 Ω at 24VDC
Operating temperature	-20 to +50 °C
Relative humidity	15-95 % (non-condensing)
Pressure range	700 to 1300 hPa
Enclosure	Aluminum with coating, optional SS
Dimensions	179 x 189 x 107 mm (HxWxD)
Weight	Aluminum: 1,3 kg Stainless Steel: 2,55 kg, Aluminum LCD: 1,75 kg Stainless Steel LCD: 3 kg
Ingress Protection	IP 66 (Sensor IP 6x)
Enclosure gas sensor	SS 316
CE marking	ATEX (Directive 2014/34/EU) Electromagnetic Compatibility (Directive 2014/30/EU)
Approvals	ATEX II 2G Ex db IICT6 Gb II 2D Ex tb IIIC T85°C Db IECEX Ex db IICT6 Gb Ex tb IIIC T85°C Db
Manufacturer	BUVECO Gasdetection BV, a Consilium Group Company

